



EDUS 39 - 600 - F7_a

R-410A

Engineering Data

FXLQ-M / FXNQ-M Floor Standing Type / Concealed Floor Standing Type



DAIKIN AC (AMERICAS), INC.

FXLQ-M / FXNQ-M Floor Standing Type / Concealed Floor Standing Type

1. Features	2
2. Specifications	3
2.1 FXLQ	3
2.2 FXNQ	4
3. Dimensions	5
3.1 FXLQ	5
3.2 FXNQ	7
4. Piping Diagrams.....	9
5. Wiring Diagrams	10
6. Electric Characteristics	11
7. Capacity Tables	12
7.1 Cooling Capacity	12
7.2 Heating Capacity	13
8. Sound Levels	14
9. Installation	15
10. Accessories	27

1. Features

Efficient for perimeter zone airconditioning.

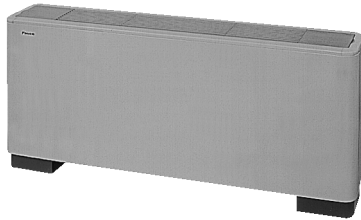

FXLQ-M

Can be built into counter

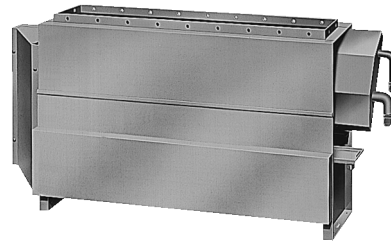

FXNQ-M

1. New roundshape is attractive in an office environment.

- Inconspicuous discharge grille and bottom frame color.
- Slim top plate for streamlined elegance.

2. Improvement ease of installation

- The piping connection work is easy to access.

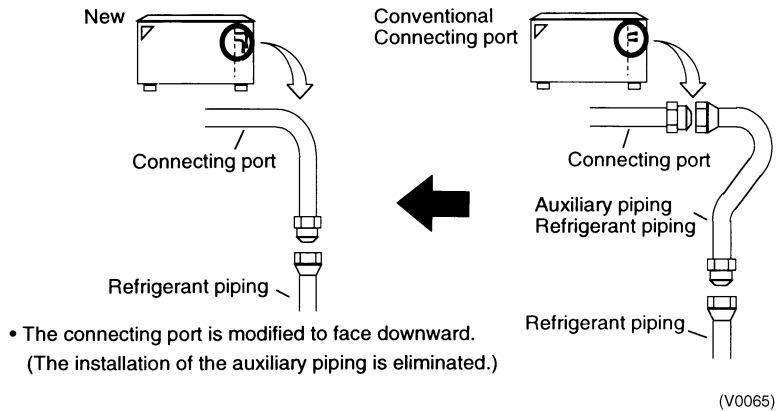

3. Easy maintenance

Wall units allow more space plus access to floor for cleaning. (Exposed type)

- Easier maintenance of discharge grille.
- The interval of filter cleaning is prolonged.

EASY MAINTENANCE

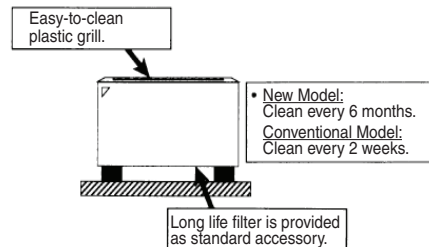
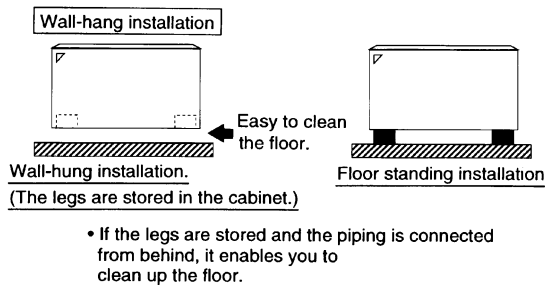

2. Specifications

2.1 FXLQ

Floor Standing Type

Model			FXLQ12MVJU	FXLQ18MVJU	FXLQ24MVJU
Cooling Capacity ¹		Btu/h	12,000	18,000	24,000
Heating Capacity ²		Btu/h	13,500	20,000	27,000
Casing Color			Ivory White (5Y7.5/1)	Ivory White (5Y7.5/1)	Ivory White (5Y7.5/1)
Dimensions: (HxWxD)		in (mm)	23-5/8 x 44-7/8 x 8-3/4" (600 x 1139.8 x 222.3 mm)	23-5/8 x 55-7/8 x 8-3/4" (600 x 1419.2 x 222.3 mm)	23-5/8 x 55-7/8 x 8-3/4" (600 x 1419.2 x 222.3 mm)
Coil (Cross Fin Coil)	Rows x Stages x FPI		3 x 14 x 17	3 x 14 x 17	3 x 14 x 17
	Face Area	ft ² (mm ²)	2.15 ft. (655.3 mm)	3.04 ft. (926.6 mm)	3.04 ft. (926.6 mm)
Fan	Model		2D14B13	2D14B20	2D14B20
	Type		Sirocco Fan	Sirocco Fan	Sirocco Fan
	Motor Output	kW	0.025	0.035	0.035
	Air Flow Rate (H/L)	cfm	280/210	490/380	560/420
Drive			Direct Drive	Direct Drive	Direct Drive
Temperature Control			Microprocessor Thermostat for Cooling and Heating	Microprocessor Thermostat for Cooling and Heating	Microprocessor Thermostat for Cooling and Heating
Sound Absorbing Thermal Insulation Material			Glass Fiber/ Urethane Foam	Glass Fiber/ Urethane Foam	Glass Fiber/ Urethane Foam
Air Filter			Resin Net (with Mold Resistant)	Resin Net (with Mold Resistant)	Resin Net (with Mold Resistant)
Piping Connections	Liquid Pipes	in / mm	φ1/4 / 6.4 mm (Flare Connection)	φ1/4 / 6.4 mm (Flare Connection)	φ3/8 / 9.5 mm (Flare Connection)
	Gas Pipes	in / mm	φ1/2 / 12.7 mm (Flare Connection)	φ1/2 / 12.7 mm (Flare Connection)	φ5/8 / 15.8 mm (Flare Connection)
	Drain Pipe	in (mm)	φ27/32" (21 mm) O.D (Vinyl Chloride)	φ27/32" (21 mm) O.D (Vinyl Chloride)	φ27/32" (21 mm) O.D (Vinyl Chloride)
Machine Weight (Mass)		Lbs	66	80	80
Sound Level (H/L) ⁴		dBA	36	40	41
Safety Devices			Fuse, Thermal Protector for Fan Motor	Fuse, Thermal Protector for Fan Motor	Fuse, Thermal Protector for Fan Motor
Refrigerant Control			Electronic Expansion Valve	Electronic Expansion Valve	Electronic Expansion Valve
Connectable Outdoor Unit			R-410A Series	R-410A Series	R-410A Series
Standard Accessories			Operation Manual, Installation Manual, Insulation for Fitting, Drain Hose, Clamps, Screws, Washers, Level Adjustment Screw.	Operation Manual, Installation Manual, Insulation for Fitting, Drain Hose, Clamps, Screws, Washers, Level Adjustment Screw.	Operation Manual, Installation Manual, Insulation for Fitting, Drain Hose, Clamps, Screws, Washers, Level Adjustment Screw.
Drawing No.			C:3D045640		

Notes:

- Nominal cooling capacities are based on the following conditions:
Return air temperature: 80°FDB, 67°FWB
Outdoor temperature: 95°FDB
Equivalent ref. piping length: 25 ft / 7.5 m (Horizontal)
- Nominal heating capacities are based on the following conditions:
Return air temperature: 70°FDB.
Outdoor temperature: 47°FDB, 43°FWB
Equivalent ref. piping length: 25 ft / 7.5 m (Horizontal)
- Capacities are net, including a deduction for cooling (an addition for heating) for indoor fan motor heat.
- Anechoic chamber conversion value, measured under JISB8616 conditions. During actual operation, these values are normally somewhat higher as a result of installation conditions.
- Refer to page 11 for Power Input.

2.2 FXNQ

Concealed Floor Standing Type

Model			FXNQ12MVJU	FXNQ18MVJU	FXNQ24MVJU
Cooling Capacity ¹		Btu/h	12,000	18,000	24,000
Heating Capacity ²		Btu/h	13,500	20,000	27,000
Casing Color			Galvanized Steel Plate	Galvanized Steel Plate	Galvanized Steel Plate
Dimensions: (HxWxD)		in (mm)	24 x 42-1/8 x 8-5/8" (609.6 x 1070 x 219mm)	24x53-1/8x8-5/8" (609.6 x 1349.4 x 219mm)	24x53-1/8x8-5/8" (609.6 x 1349.4 x 219mm)
Coil (Cross Fin Coil)	Rows x Stages x FPI		3 x 14 x 17	3 x 14 x 17	3 x 14 x 17
	Face Area	ft ² (mm ²)	2.15 ft. (655.3 mm)	3.04 ft. (926.6 mm)	3.04 ft. (926.6 mm)
Fan	Model		2D14B13	2D14B20	2D14B20
	Type		Sirocco Fan	Sirocco Fan	Sirocco Fan
	Motor Output	kW	0.025	0.035	0.035
	Air Flow Rate (H/L)	cfm	280/210	490/380	560/420
	Drive		Direct Drive	Direct Drive	Direct Drive
Temperature Control			Microprocessor Thermostat for Cooling and Heating	Microprocessor Thermostat for Cooling and Heating	Microprocessor Thermostat for Cooling and Heating
Sound Absorbing Thermal Insulation Material			Glass Fiber/ Urethane Foam	Glass Fiber/ Urethane Foam	Glass Fiber/ Urethane Foam
Air Filter			Resin Net (with Mold Resistant)	Resin Net (with Mold Resistant)	Resin Net (with Mold Resistant)
Piping Connections	Liquid Pipes	in / mm	φ1/4 / 6.4 mm (Flare Connection)	φ1/4 / 6.4 mm (Flare Connection)	φ3/8 / 9.5 mm (Flare Connection)
	Gas Pipes	in / mm	φ1/2 / 12.7 mm (Flare Connection)	φ1/2 / 12.7 mm (Flare Connection)	φ5/8 / 15.8 mm (Flare Connection)
	Drain Pipe	in / mm	φ27/32 (685.8 / 812.8 mm) O.D (Vinyl Chloride)	φ27/32 (685.8 / 812.8 mm) O.D (Vinyl Chloride)	φ27/32 (685.8 / 812.8 mm) O.D (Vinyl Chloride)
Machine Weight (Mass)		Lbs	51	60	60
Sound Level (H/L) ⁴		dBA	36	40	41
Safety Devices			Fuse, Thermal Protector for Fan Motor	Fuse, Thermal Protector for Fan Motor	Fuse, Thermal Protector for Fan Motor
Refrigerant Control			Electronic Expansion Valve	Electronic Expansion Valve	Electronic Expansion Valve
Connectable Outdoor Unit			R-410A Series	R-410A Series	R-410A Series
Standard Accessories			Operation Manual, Installation Manual, Insulation for Fitting, Drain Hose, Clamps, Screws, Washers, Level Adjustment Screw.	Operation Manual, Installation Manual, Insulation for Fitting, Drain Hose, Clamps, Screws, Washers, Level Adjustment Screw.	Operation Manual, Installation Manual, Insulation for Fitting, Drain Hose, Clamps, Screws, Washers, Level Adjustment Screw.
Drawing No.			3D045640		

Notes:

- Nominal cooling capacities are based on the following conditions:
Return air temperature: 80°FDB, 67°FWB
Outdoor temperature: 95°FDB
Equivalent ref. piping length: 25 ft / 7.5 m (Horizontal)
- Nominal heating capacities are based on the following conditions:
Return air temperature: 70°FDB.
Outdoor temperature: 47°FDB, 43°FWB
Equivalent ref. piping length: 25 ft / 7.5 m (Horizontal)
- Capacities are net, including a deduction for cooling (an addition for heating) for indoor fan motor heat.
- Anechoic chamber conversion value, measured under JISB8616 conditions. During actual operation, these values are normally somewhat higher as a result of installation conditions.
- Refer to page 11 for Power Input.

3. Dimensions

3.1 FXLQ

FXLQ12MVJU

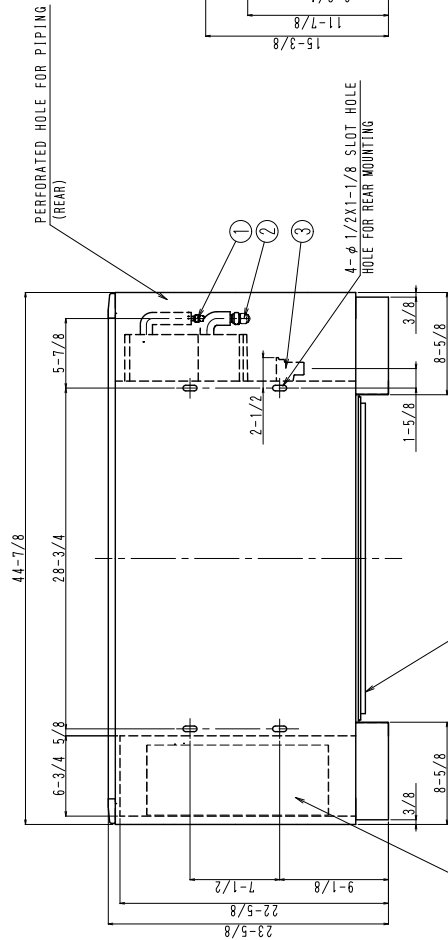
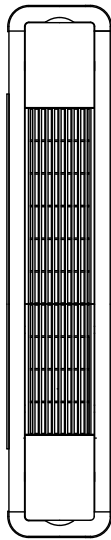
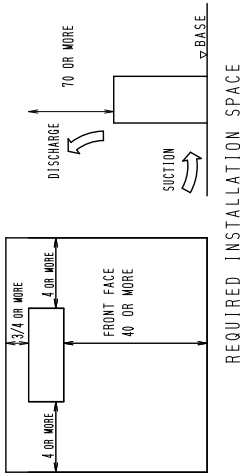

NOTE)
1. LOCATION OF UNIT'S NAME PLATE:
OUTSIDE SURFACE OF RIGHT SIDE PLATE.

NUMBER	NAME	DESCRIPTION
1	LIQUID PIPE CONNECTION PORT	φ 1/4 FLARE CONNECTION
2	GAS PIPE CONNECTION PORT	φ 1/2 FLARE CONNECTION
3	DRAIN PIPE CONNECTION PORT	φ, D, 27/32
4	ELECTRIC PARTS BOX	
5	AIR FILTER	

9D045642

FXLQ18MVJU
FXLQ24MVJU

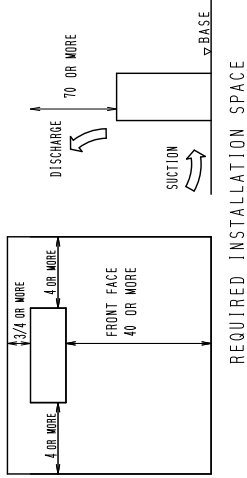

REQUIRED INSTALLATION SPACE

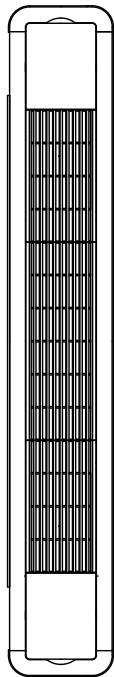

Piping size (field supply)

Indoor unit	Gas side	Liquid side
FXLQ18MVJU	φ 1/2	φ 1/4
FXLQ24MVJU	φ 5/8	φ 3/8

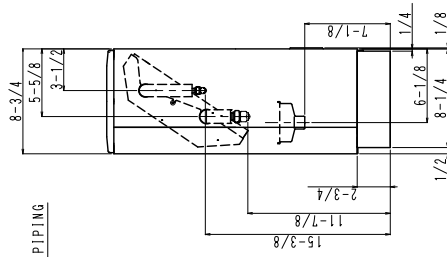

NOTE)
1. LOCATION OF UNIT'S NAME PLATE:
OUTSIDE SURFACE OF RIGHT SIDE PLATE.

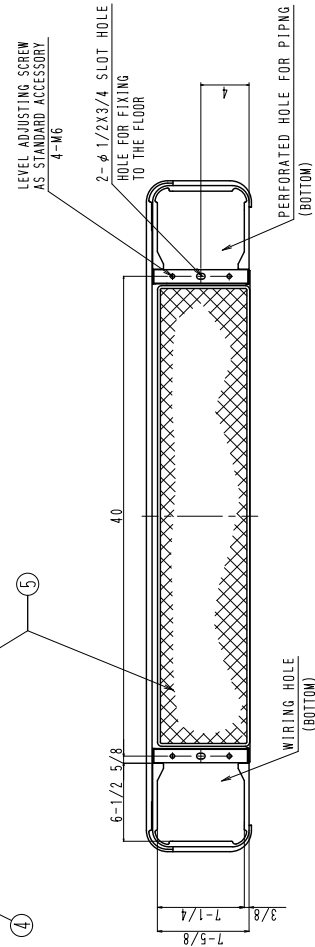
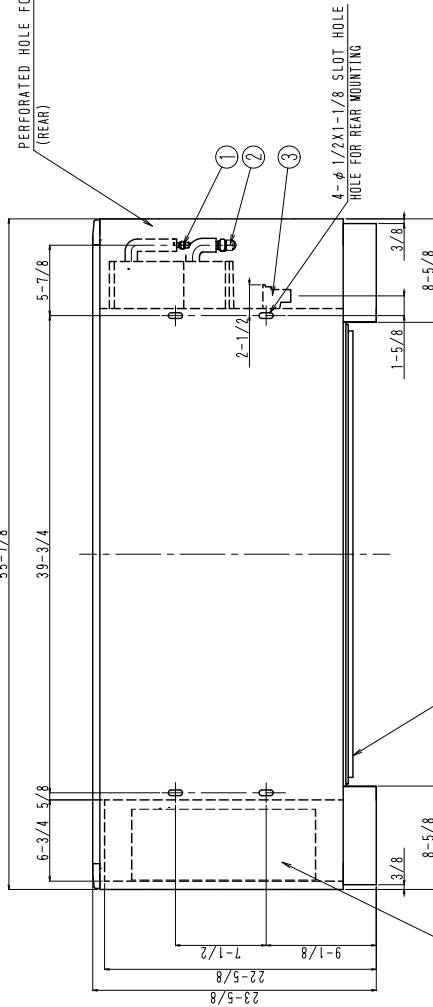

NUMBER	NAME	DESCRIPTION
1	LIQUID PIPE CONNECTION	FLARE CONNECTION
2	GAS PIPE CONNECTION	FLARE CONNECTION
3	DRAIN PIPE CONNECTION PORT	O. D. 27/32
4	ELECTRIC PARTS BOX	
5	AIR FILTER	

3D046643

3.2 FXNQ

FXNQ12MVJU

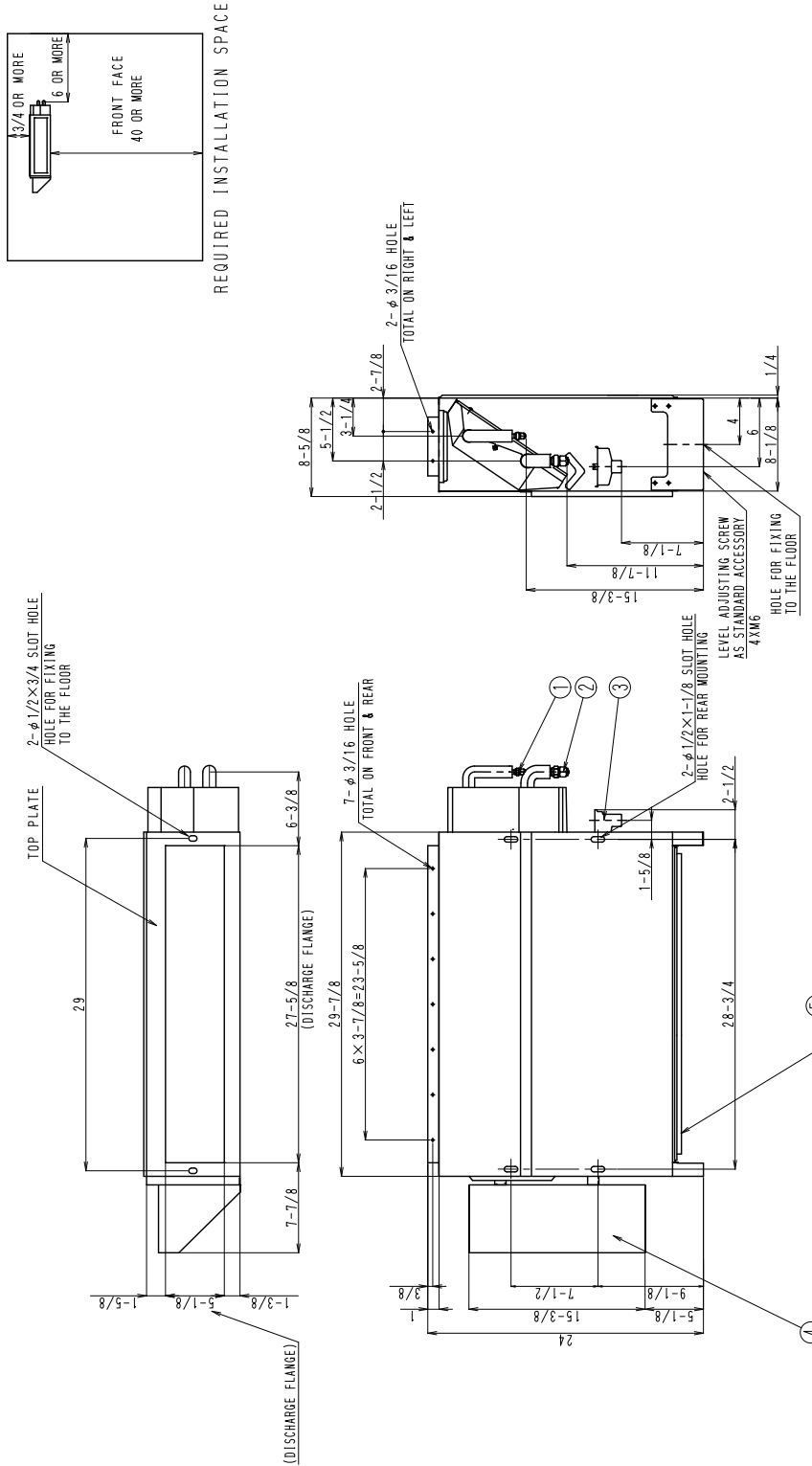

NUMBER	NAME	DESCRIPTION
1	LIQUID PIPE CONNECTION PORT	φ 1/4 FLARE CONNECTION
2	GAS PIPE CONNECTION PORT	φ 1/2 FLARE CONNECTION
3	DRAIN PIPE CONNECTION PORT	O, D. 27/32
4	ELECTRIC PARTS BOX	
5	AIR FILTER	

3D045650

FXNQ18MVJU
FXNQ24MVJU

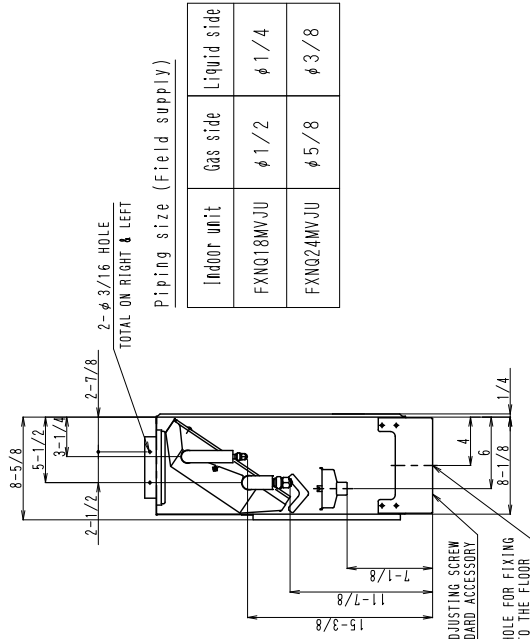
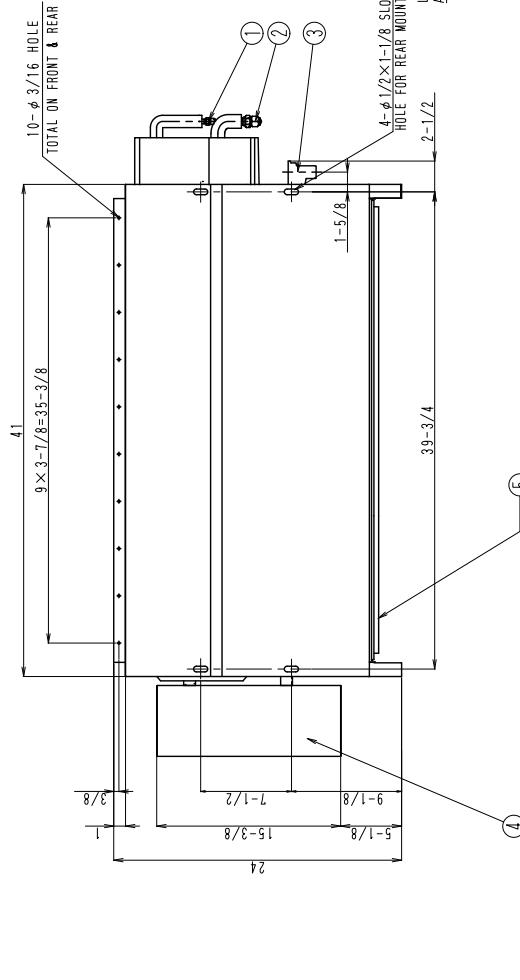
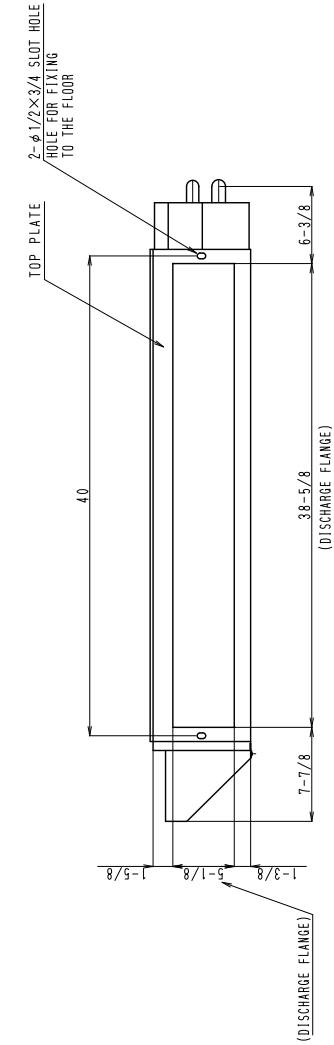
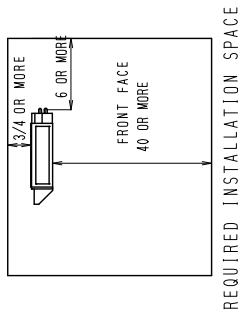

NUMBER	NAME	DESCRIPTION
1	LIQUID PIPE CONNECTION PORT	FLARE CONNECTION
2	GAS PIPE CONNECTION	FLARE CONNECTION
3	DRAIN PIPE CONNECTION	O. D. 27/32
4	ELECTRIC PARTS BOX	
5	AIR FILTER	

3D045651

1. LOCATION OF UNIT'S NAME PLATE :
THE RIGHT LOWER CORNER OF FRONT PLATE

4. Piping Diagrams

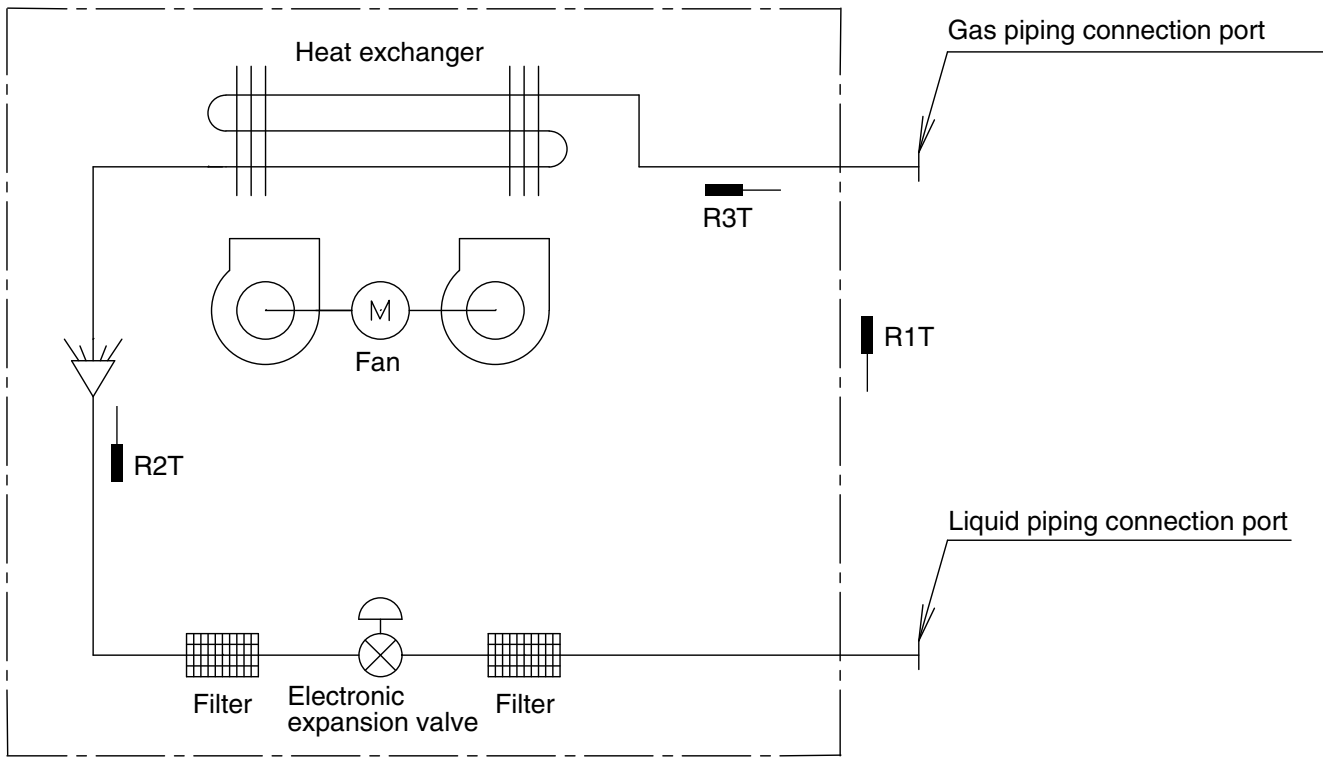

C:4D034245C

- R1T : Thermistor for suction air temperature
- R2T : Thermistor for liquid line temperature
- R3T : Thermistor for gas line temperature

Capacity	GAS	Liquid
12/18M	φ1/2	φ1/4
24M	φ5/8	φ3/8

6. Electric Characteristics

Units				Power supply		IFM		Input(W)	
Model	Hz	Volts	Voltage range	MCA	MFA	KW	FLA	Cooling	Heating
FXLQ • FXNQ12MVJU	60	208-230	MAX. 253 Min. 187	0.5	15	0.025	0.4	79	79
FXLQ • FXNQ18MVJU				0.6	15	0.035	0.5	105	105
FXLQ • FXNQ24MVJU				0.6	15	0.035	0.5	108	108

Symbols :

MCA : Min. Circuit Amps (A)
 MFA : Max. Fuse Amps (See note 5)
 KW : Fan Motor Rated Output(KW)
 FLA : Full Load Amps(A)
 IFM : Indoor Fan Motor

Note :

1. Voltage range

Units are suitable for use on electrical systems where voltage supplied to unit terminals is not below or above listed range limits,

2. Maximum allowable voltage unbalance between phases is 2%.

3. MCA/MFA

$$MCA = 1.25 \times FLA$$

$$MFA \leq 4 \times FLA$$

(Next lower standard fuse rating. Min. 15A)

4. Select wire size based on the MCA.

5. Instead of fuse, use Circuit Breaker.

4D047090

7. Capacity Tables

7.1 Cooling Capacity

FXLQ-M / FXNQ-M

		Cooling capacity											
Unit size	Outdoor air temp.	Indoor Air Temp. °FWB											
		61		64		67		70		72		75	
	°FDB	TC	SHC	TC	SHC	TC	SHC	TC	SHC	TC	SHC	TC	SHC
12	75	9.5	7.5	10.7	7.9	12.0	8.3	13.3	8.4	14.0	8.4	14.3	7.9
	79	9.5	7.5	10.7	7.9	12.0	8.3	13.3	8.4	13.8	8.4	14.0	7.8
	83	9.5	7.5	10.7	7.9	12.0	8.3	13.3	8.4	13.6	8.3	13.8	7.7
	87	9.5	7.5	10.7	7.9	12.0	8.3	13.2	8.4	13.3	8.1	13.6	7.7
	91	9.5	7.5	10.7	7.9	12.0	8.3	13.0	8.4	13.1	8.1	13.4	7.6
	95	9.5	7.5	10.7	7.9	12.0	8.3	12.7	8.4	12.9	8.0	13.1	7.6
	99	9.5	7.5	10.7	7.9	12.0	8.3	12.5	8.4	12.7	7.9	12.9	7.6
	103	9.5	7.5	10.7	7.9	12.0	8.3	12.3	8.3	12.4	7.8	12.7	7.6
18	75	14.2	10.7	16.1	11.5	18.0	12.2	19.9	12.7	21.0	12.8	21.4	12.2
	79	14.2	10.7	16.1	11.5	18.0	12.2	19.9	12.7	20.7	12.7	21.1	12.0
	83	14.2	10.7	16.1	11.5	18.0	12.2	19.9	12.7	20.4	12.6	20.7	11.9
	87	14.2	10.7	16.1	11.5	18.0	12.2	19.8	12.7	20.0	12.4	20.4	11.7
	91	14.2	10.7	16.1	11.5	18.0	12.2	19.4	12.6	19.7	12.3	20.1	11.6
	95	14.2	10.7	16.1	11.5	18.0	12.2	19.1	12.6	19.3	12.1	19.7	11.4
	99	14.2	10.7	16.1	11.5	18.0	12.2	18.8	12.6	19.0	12.0	19.4	11.2
	103	14.2	10.7	16.1	11.5	18.0	12.2	18.4	12.4	18.7	11.9	19.0	11.0
24	75	18.9	14.1	21.5	15.1	24.0	15.9	26.5	16.6	28.0	16.6	28.5	16.0
	79	18.9	14.1	21.5	15.1	24.0	15.9	26.5	16.6	27.6	16.6	28.1	15.7
	83	18.9	14.1	21.5	15.1	24.0	15.9	26.5	16.6	27.1	16.4	27.6	15.5
	87	18.9	14.1	21.5	15.1	24.0	15.9	26.4	16.6	26.7	16.2	27.2	15.2
	91	18.9	14.1	21.5	15.1	24.0	15.9	25.9	16.6	26.2	16.0	26.7	15.0
	95	18.9	14.1	21.5	15.1	24.0	15.9	25.5	16.5	25.8	15.8	26.3	14.7
	99	18.9	14.1	21.5	15.1	24.0	15.9	25.0	16.5	25.3	15.6	25.8	14.5
	103	18.9	14.1	21.5	15.1	24.0	15.9	24.6	16.3	24.9	15.4	25.4	14.2

TC : Total capacity ; kW
SHC : Sensible heat capacity ; kW



Refer to Outdoor Unit Capacity Tables : for the actual performance data of each indoor and outdoor unit combination.

7.2 Heating Capacity

FXLQ-M / FXNQ-M

Indoor unit	Outdoor Air Temp.		Indoor Air Temp. °FDB					
			62	65	68	70	72	75
			TC	TC	TC	TC	TC	TC
	°FDB	°FWB	MBh	MBh	MBh	MBh	MBh	MBh
12	22.0	20.0	11.7	11.7	11.6	11.6	11.6	11.6
	26.0	24.0	12.2	12.2	12.2	12.2	12.2	12.1
	30.0	28.0	12.8	12.8	12.7	12.7	12.7	12.3
	35.0	32.0	13.3	13.3	13.3	13.3	13.0	12.3
	39.0	36.0	13.9	13.9	13.9	13.5	13.0	12.3
	44.0	40.0	14.5	14.4	14.0	13.5	13.0	12.3
	47.0	43.0	14.9	14.7	14.0	13.5	13.0	12.3
	51.0	47.0	15.4	14.7	14.0	13.5	13.0	12.3
	54.0	50.0	15.5	14.7	14.0	13.5	13.0	12.3
	57.0	53.0	15.5	14.7	14.0	13.5	13.0	12.3
60.0	56.0	15.5	14.7	14.0	13.5	13.0	12.3	
18	22.0	20.0	17.5	17.5	17.4	17.4	17.4	17.4
	26.0	24.0	18.3	18.3	18.3	18.3	18.2	18.2
	30.0	28.0	19.2	19.1	19.1	19.1	19.1	18.4
	35.0	32.0	20.0	20.0	19.9	19.9	19.5	18.4
	39.0	36.0	20.8	20.8	20.8	20.0	19.5	18.4
	44.0	40.0	21.7	21.6	21.0	20.0	19.5	18.4
	47.0	43.0	22.3	22.1	21.0	20.0	19.5	18.4
	51.0	47.0	23.1	22.1	21.0	20.0	19.5	18.4
	54.0	50.0	23.2	22.1	21.0	20.0	19.5	18.4
	57.0	53.0	23.2	22.1	21.0	20.0	19.5	18.4
60.0	56.0	23.2	22.1	21.0	20.0	19.5	18.4	
24	22.0	20.0	23.3	23.3	23.3	23.2	23.2	23.2
	26.0	24.0	24.5	24.4	24.4	24.3	24.3	24.3
	30.0	28.0	25.6	25.5	25.5	25.5	25.4	24.5
	35.0	32.0	26.7	26.6	26.6	26.6	26.0	24.5
	39.0	36.0	27.8	27.7	27.7	27.0	26.0	24.5
	44.0	40.0	28.9	28.9	28.0	27.0	26.0	24.5
	47.0	43.0	29.7	29.5	28.0	27.0	26.0	24.5
	51.0	47.0	30.8	29.5	28.0	27.0	26.0	24.5
	54.0	50.0	31.0	29.5	28.0	27.0	26.0	24.5
	57.0	53.0	31.0	29.5	28.0	27.0	26.0	24.5
60.0	56.0	31.0	29.5	28.0	27.0	26.0	24.5	



Refer to Outdoor Unit Capacity Tables : for the actual performance data of each indoor and outdoor unit combination.

8. Sound Levels

Overall

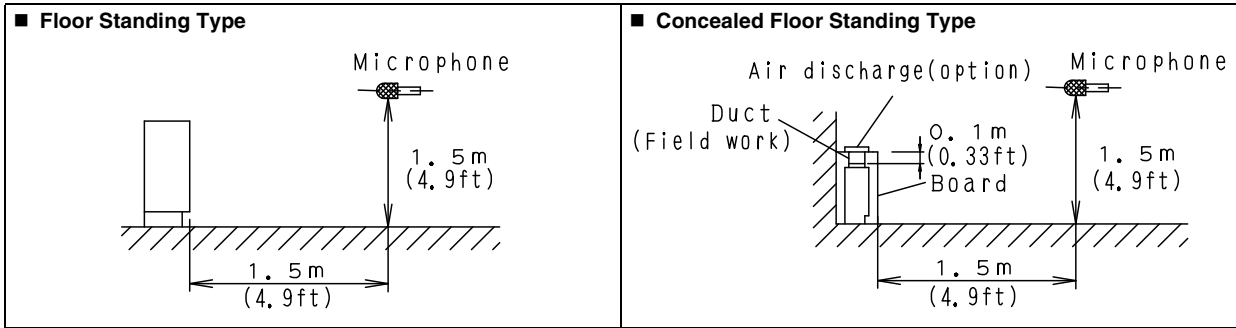

dB(A)

Model	208~230V, 60Hz		Model	208~230V, 60Hz	
	H	L		H	L
FXLQ12MVJU	36	33	FXNQ12MVJU	36	33
FXLQ18MVJU	40	35	FXNQ18MVJU	40	35
FXLQ24MVJU	41	36	FXNQ24MVJU	41	36

Note: Operation noise differs with operation and ambient conditions.

Octave Band Level

○ ○ 208V~230V

FXLQ12MVJU

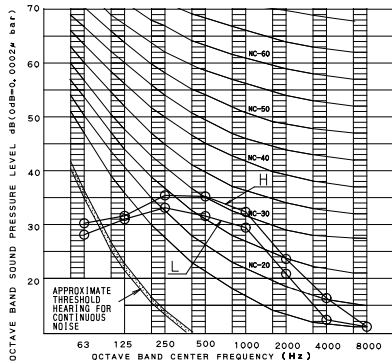

FXLQ18MVJU

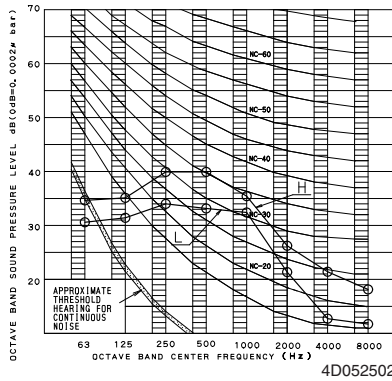

FXLQ24MVJU

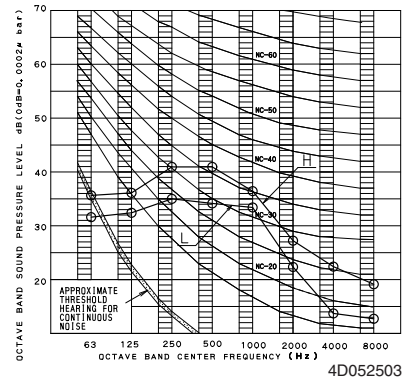

FXNQ12MVJU

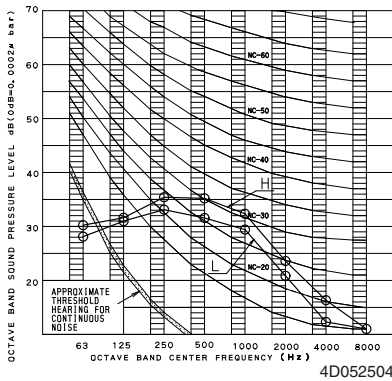

FXNQ18MVJU

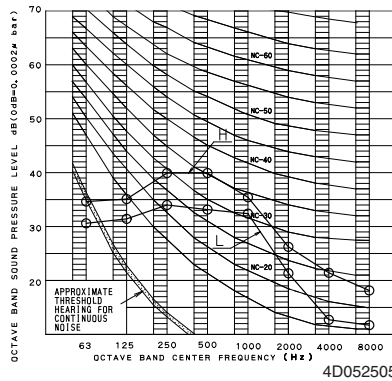

FXNQ24MVJU

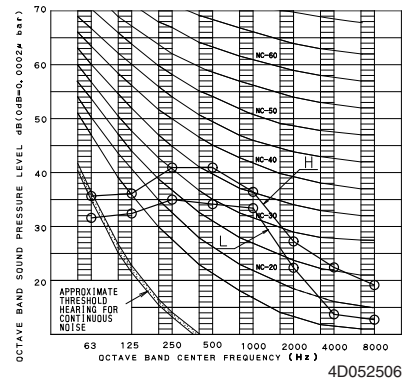

9. Installation

Installation Example

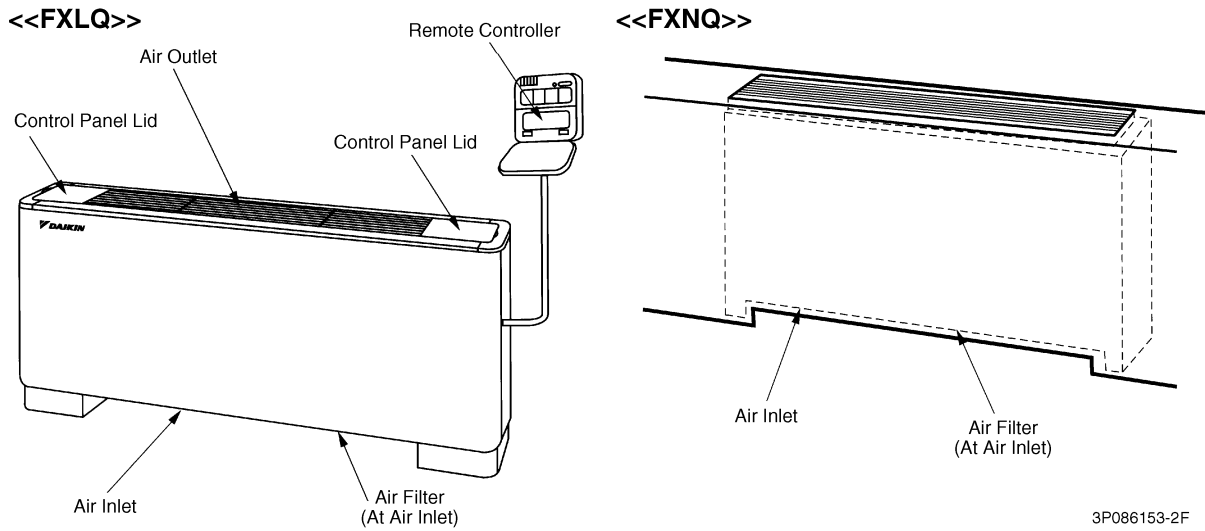

Center of Gravity

FXLQ

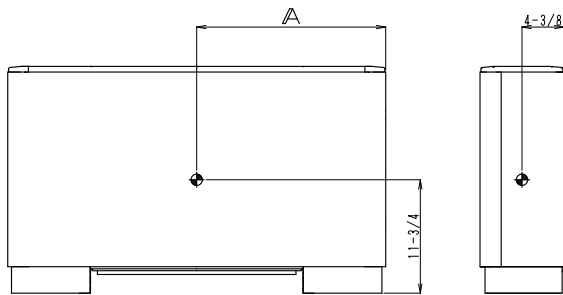

MODEL	A
FXLQ12MVJU	22-1/2
FXLQ18•24MVJU	28

4D045645

FXNQ

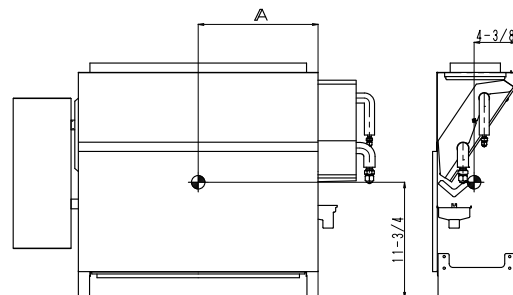

MODEL	A
FXNQ12MVJU	18-1/4
FXNQ18•24MVJU	19-7/8

4D045652





1. SAFETY CONSIDERATIONS

Read these "SAFETY CONSIDERATIONS" carefully before installing air conditioning equipment, and be sure to install it correctly. After completing the installation, make sure that the unit operates properly during the start-up operation.

Instruct the customer how to operate and maintain the unit. Inform customers that they should store this Installation Manual with the Operation Manual for future reference.

Always use a licensed installer or contractor to install this product. Improper installation can result in water or refrigerant leakage, electrical shock, fire, or explosion.

Meanings of DANGER, WARNING, CAUTION, and NOTE symbols:

-  **DANGER** Indicates an imminently hazardous situation which, if not avoided, results in death or serious injury.
-  **WARNING** Indicates a potentially hazardous situation which, if not avoided, could result in death or serious injury.
-  **CAUTION** Indicates a potentially hazardous situation which, if not avoided, may result in minor or moderate injury. It may also be used to alert against unsafe practices
-  **NOTE** Indicates situations that may result in equipment or property damage accidents only.

- **Do not ground units to water pipes or telephone wires because incomplete grounding could cause a severe shock hazard resulting in severe injury or death. Do not ground ss to lightning rods because lightning strikes can cause a severe shock hazard resulting in severe injury or death. Do not install unit in an area where flammable materials are present due to risk of explosion resulting in serious injury or death.**
- **Do not ground units to gas pipes because a gas leak can result in an explosion causing serious injury or death.**
- **Refrigerant gas is heavier than air and displaces oxygen. A massive leak can lead to oxygen depletion, especially in basements, and an asphyxiation hazard could occur leading to serious injury or death.**
- **If the refrigerant gas leaks during installation, ventilate the area immediately.**
Refrigerant gas may produce toxic gas if it comes in contact with fire such as from a fan, heater, stove, or cooking device. Exposure to this gas could result in severe injury or death.
- **After completing the installation work, check that the refrigerant gas does not leak.**
Refrigerant gas can produce toxic gas if it comes in contact with fire such as from a fan, heater, stove, or cooking device. Exposure to this gas can cause in severe injury or death.
- **Children playing with plastic bags face the danger of death by suffocation. Tear apart and throw away plastic packaging so that children will not play with them.**

- **Safely dispose of the packing materials.** Packing materials, such as nails and other metal or wooden parts, may cause stabs or other injuries.

WARNING

- **Ask your dealer or an authorized personnel to carry out installation work. Do not try to install the unit by yourself.**
Improper installation may result in water leakage, electric shocks, or fire.
- **Perform installation work in accordance with this installation manual.**
Improper installation may result in water leakage, electric shocks, or fire.
- **Be sure to use only the specified accessories and parts for installation work.**
Failure to use the specified parts may result in water leakage, electric shocks, fire, or the unit falling.
- **Install the air conditioner on a foundation strong enough to withstand the weight of the unit.**
A foundation of insufficient strength may result in the equipment falling and causing injuries.
- **Carry out the specified installation work after taking account of strong winds, typhoons, or earthquakes.**
Improper installation work may result in the equipment falling and causing accidents.
- **Make sure that a separate power supply circuit is provided for this unit and that all electrical work is carried out by an authorized personnel according to local laws, regulations, and this installation manual.**
An insufficient power supply capacity or improper electrical construction may lead to electric shocks, or fire.
- **Make sure that all wiring is secured, the specified wires are used, and no external forces act on the terminal connections or wires.**
Improper connections or installation may result in fire.
- **When wiring the power supply and connecting the remote controller wiring and transmission wiring, position the wires so that the electric parts box lid can be securely fastened.**
Improper positioning of the electric parts box lid may result in electric shocks, fire, or the terminals overheating.
- **Before touching electrical parts, turn off the unit.**
- **Do not touch the switch with wet fingers.**
Touching a switch with wet fingers can cause electric shock.
- **Be sure to install an earth leakage breaker.**
Failure to install a ground leakage breaker may result in electric shocks, or fire.
- **Do not install the air conditioner where the following conditions exist:**
 - (a) Mineral oil mist or an oil spray or vapor is produced, for example in a kitchen.
Plastic parts may deteriorate and fall off or water may leak.
 - (b) Corrosive gas, such as sulfurous acid gas, is produced.
Corroding copper pipes or soldered parts can cause refrigerant leaks.
 - (c) Machinery is emitting electromagnetic waves.
Electromagnetic waves may disturb the operation of the control system and result in a malfunction of the equipment.
 - (d) Where flammable gases may leak, where there are carbon fiber or ignitable dust suspensions in

the air, or where volatile liquids such as thinner or gasoline are handled.

Operating the unit in such conditions may result in fire.

- **Heat exchanger fins are sharp enough to cause cuts.**
To avoid injury wear gloves or cover the fins when you are working around them.
- **Refrigerant pipes may be very hot or very cold during or immediately after operation.**



CAUTION

- **While following the instructions in this installation manual, insulate piping in order to prevent condensation.**
Improper piping insulation may result in water leakage and property damage.
- **Be very careful about product transportation.**
Some products use PP bands for packaging. Do not use any PP bands for a means of transportation. It is dangerous.
- **Safely dispose of the packing materials.**
Packing materials, such as nails and other metal or wooden parts, may cause stabs or other injuries.
Tear apart and throw away plastic packaging bags so that children do not play with them. If children play with a plastic bag which was not torn apart, they face the risk of suffocation.
- **Do not turn off the power immediately after stopping operation.**
Always wait at least five minutes before turning off the power. Otherwise, water leakage or other problems may occur.
- **Make sure to provide for adequate measures in order to prevent that the outdoor unit be used as a shelter by small animals.**
Small animals making contact with electrical parts can cause malfunctions, smoke, or fire. Please instruct the customer to keep the area around the unit clean.



NOTE

- **Install the indoor and outdoor units, power supply wiring and connecting wires at least 3.5 ft. away from televisions or radios in order to prevent image interference or noise.**
Depending on the radio waves, a distance of 3.5 ft. may not be enough to eliminate the noise.
- **Remote controller (wireless kit) transmitting distance is shorter than expected in rooms with electronic fluorescent lamps**
- **Radio interference may result if installed too close to other electrical devices. Dismantling of the unit, and treatment of the refrigerant, oil, and other parts, should be done in accordance with the relevant local and national regulations.**

2. BEFORE INSTALLATION

- **Be sure to read this manual before installing the indoor unit**
- **When moving the unit while removing it from the packing case, be sure to lift it by the four hanger brackets. Avoid putting any pressure on other parts especially the refrigerant piping. Be sure to check the type of R-410A refrigerant to be used before installing the unit as**

using an incorrect refrigerant prevents normal operation of the unit.

- The accessories needed for installation must be retained in your custody until the installation work is completed. Do not discard them!
- Decide upon a line of transport.
- Leave the unit inside its packaging while moving until reaching the installation site. If unpacking is unavoidable, use a sling of soft material or protective plates together with a rope when lifting, to avoid damage or scratches to the unit.
- For the installation of an outdoor unit, refer to the installation manual attached to the outdoor unit.
- Do not install or operate the unit in rooms where the following conditions might exist:
 - **Laden with mineral oil, or filled with oil vapor or spray such as in kitchens. Plastic parts may deteriorate which could eventually cause the unit to fall out of place, or could lead to leaks.**
 - **Corrosive gas such as sulfurous gas exists. Copper tubing and brazed spots may corrode which could lead to refrigerant leaks.**
 - **Machines generating electromagnetic waves that can cause the Control System to malfunction.**
 - **Where the air contains high levels of salt such as near the ocean, and where voltage fluctuates greatly such as in factories.**
Also in vehicles or vessels.
- This unit, both indoor and outdoor, is suitable for installation in a commercial and light industrial environment. If installed as a household appliance it could cause electromagnetic interference.







WARNING

- **Entrust installation to the place of purchase or an authorized serviceman. Improper installation could lead to leaks and, in worse cases, electric shock or fire. Use of unspecified parts could lead to the unit falling, leaks and, in worse cases, electric shock or fire.**

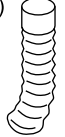
2-1 ACCESSORIES

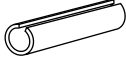
Check to ensure the following accessories are included with your unit.

Name	Drain hose	Insulation for fitting
Quantity	1 set	1 each
Shape	Hose x 1 Metal clamp x 1 (1)  (2) 	(3) For gas pipe  (4) For liquid pipe 

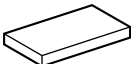
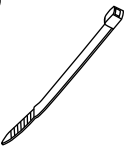
Name	Sealing pad	Clamp
Quantity	1 pc.	8 pcs.
Shape	(5) 	(6) 

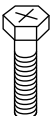
Name	Leveling screw	[Other] • Operation manual • Installation manual
Quantity	4 pcs.	
Shape	(7) 	

2-2 OPTIONAL ACCESSORIES

Table 1

Remote controller	
Wired type	BRC1D71

FOR THE FOLLOWING ITEMS, TAKE SPECIAL CARE DURING CONSTRUCTION AND CHECK AFTER INSTALLATION IS FINISHED.

a. Items to be checked after completion of work

Items to be checked:	If not properly done, the following can occur:	Check
Are the indoor and outdoor units fixed firmly?	Units may drop, vibrate or make noise.	
Is the gas leak test finished?	insufficient cooling	
Is the unit fully insulated?	Dripping condensate water	
Does drainage flow smoothly?	Dripping condensate water	
Does the power supply voltage correspond to that shown on the name plate?	Unit may malfunction or the components burn out.	

Are wiring and piping correct?	Unit may malfunction or the components burn out.	
Is the unit safely grounded?	Danger of electric leakage.	
Is wiring size according to specifications?	Unit may malfunction or the components burn out.	
Is something blocking the air outlet or inlet of either the indoor or outdoor units?	insufficient cooling	
Are refrigerant piping length and additional refrigerant charge noted down?	Refrigerant charge in the system is not clear.	

b. Items to be checked at time of delivery

Also review the **SAFETY CONSIDERATIONS** on the previous page.

Items to be checked:	Check
Did you explain about operations while showing the operation manual to your customer?	
Did you hand the operation manual over to your customer?	

2-3 NOTE TO THE INSTALLER

Be sure to instruct customers how to properly operate the unit, especially cleaning filters, operating different functions, and adjusting the temperature.) Have them carry out operations themselves while looking at the manual.

3. SELECTING INSTALLATION SITE

- **Select an installation site that meets with your customer's approval and where the following conditions are satisfied:** Floor is strong enough to bear the indoor unit weight.
- Floor is not significantly inclined.
- Nothing blocks the air passage.
- Condensate can be properly drained.
- Sufficient clearance for installation and maintenance can be ensured.
- Optimum air distribution can be ensured.
- No risk of flammable gas leakage.
- Piping between indoor and outdoor units is possible within the allowable limit. (Refer to the installation manual of the outdoor unit.)

! WARNING

- If the supporting structural members are not strong enough to take the unit's weight, the unit could fall out of place and cause serious injury.
- Do not install unit in an area where flammable materials are present due to the risk of explosion resulting in serious injury or death.

! NOTE

- Install the indoor and outdoor units, power supply wiring and connecting wires at least 3.5 ft. away from televisions or radios in order to prevent image interference or noise. (Depending on the radio waves, a distance of 3.5 ft. may not be enough to eliminate the noise.)

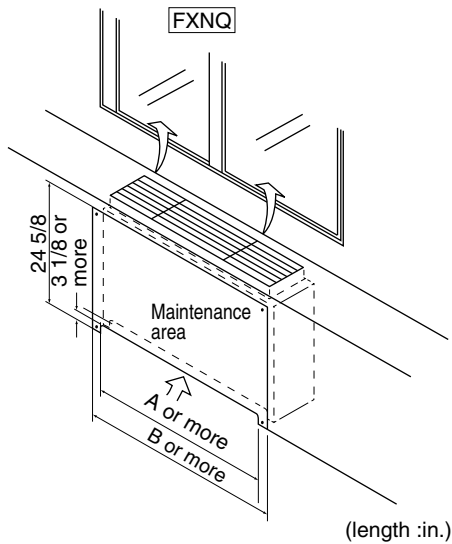
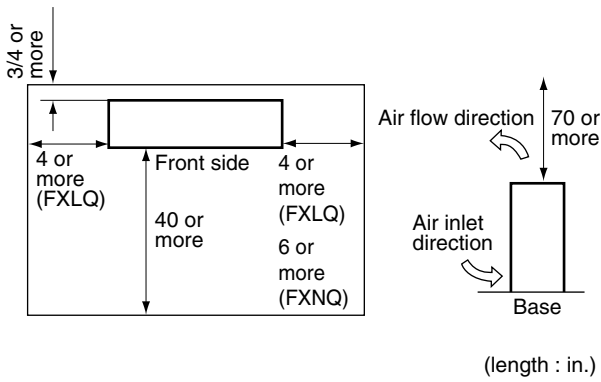
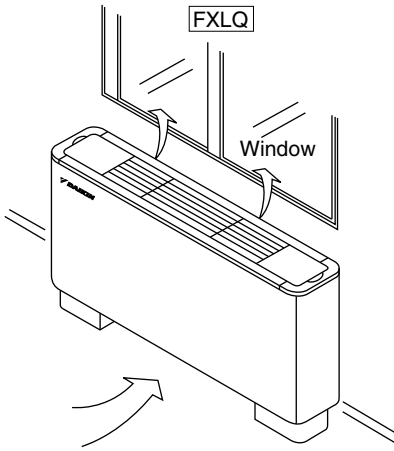

(IMPORTANT) Leave sufficient clearance for air inlet and maintenance.

Model	A (in.)	B (in.)
FXNQ12MVJU	28	46
FXNQ18 · 24MVJU	39	57

4. PREPARATIONS BEFORE INSTALLATION

(1) Positioning of holes for fastening to the wall

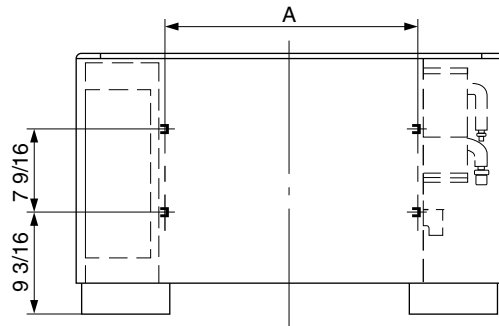

Model	A (in.)
12 type	28 3/4
18 · 24 type	39 3/4

(2) How to open / close the front panel (FXLQ)

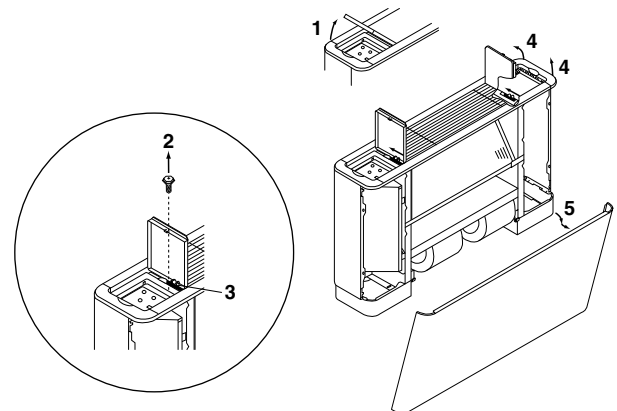

1. Open the lid of control panel (both left and right).
 2. Remove screws (both left and right) that lock the knobs in position.
 3. Push the knobs (both left and right) to the rear.
 4. Lift the front of the top plate.
 5. Lower the front panel towards the front of the unit.
- To close, perform the procedure in opposite order by pulling toward the front of the unit until the knob snaps in place.

5. INDOOR UNIT INSTALLATION

As for the parts to be used for installation work, be sure to use the provided accessories and specific Daikin parts.

- (1) **Level the indoor unit with the leveling screws (7). If the floor is too uneven to level the unit, place the unit on a flat surface and level it.**

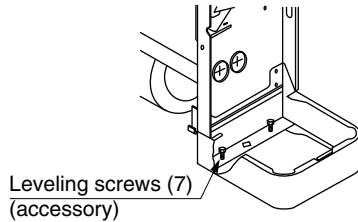

- (2) **If the unit is in danger of falling over, either fasten to the wall using the holes provided, or fasten to the floor with an optional floor fastener.**
- (3) **The legs can be retracted if the indoor unit is to be hung on a wall. To do so, lift the legs as shown in the following figure.**

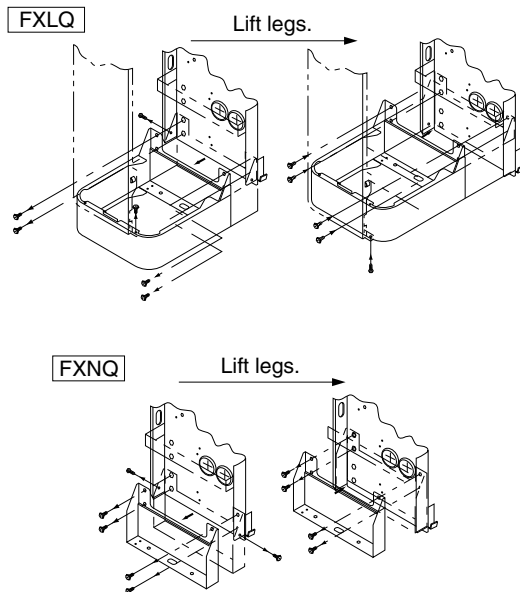

NOTE

- Use the installation mount for installation. Check whether the wall is strong enough to bear the weight of the unit or not. If there is a risk, reinforce the wall before installing the unit.
- The unit requires a minimum 2.5 inch clearance on the underside for air intake. Ensure the unit is level when installed so that drainage flows smoothly. If tilted or on an incline, water can leak.
- Operating sound may be louder if installed on a more solid wall.

- (4) **Perform the following procedure to mount the optional remote controller on the unit if desired. (FXLQ type only)**
- (5) **Open the left side of control panel and mount the lower case of the remote controller.**

See the installation manual attached to the remote controller for instructions on fastening screws and wiring the remote controller.

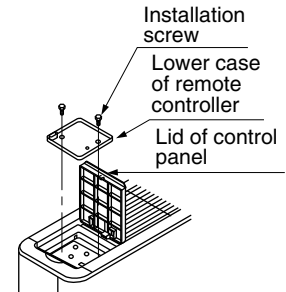

NOTE

- Setting the unit at an angle opposite to the drain piping might cause leaks.

6. REFRIGERANT PIPING WORK

For refrigerant piping of outdoor units, see the installation manual attached to the outdoor unit.

Execute heat insulation work completely on both sides of the gas piping and the liquid piping. Otherwise, a water leakage can result.

When using a heat pump, the temperature of the gas piping can reach up to approximately 250°F, so use sufficiently resistant insulation.

In cases where the temperature and humidity of the refrigerant piping sections might exceed 86°F or RH80%, reinforce the refrigerant insulation by 13/16" or thicker. Condensate may form on the surface of the insulating material.

Before refrigerant piping work, check which type of refrigerant is used. Proper operation is not possible if the types of refrigerant are not the same.

NOTE

- Use a pipe cutter and flare suitable for the type of refrigerant.
- To prevent dust, moisture or other foreign matter from infiltrating the tube, either pinch the end or cover it with tape.
- Do not allow anything other than the designated refrigerant to get mixed into the refrigerant circuit, such as air, etc.
- If any refrigerant gas leaks while working on the unit, immediately ventilate the room.

When connecting refrigerant piping:

- Ensure that the outdoor unit is charged with refrigerant.
- Use copper alloy seamless pipes.
- To prevent flare nut cracking and gas leaks, be sure to use both a spanner and torque wrench together, as shown in the drawing, when connecting or disconnecting pipes to / from the unit.
- Refer to Table 2 for the dimensions of flare.

- When connecting the flare nut, coat the flare section (both inside and outside) with ester oil or ether oil, rotate three or four times first, then screw in.
 - Refer to the Table 2 for tightening torque.
 - After inspecting pipe joints for gas leakage, be sure to insulate with the accessory joint insulation for fitting (3) (4) while referring to the figure below. Fasten both ends with clamps (6).
- Wrap only the gas line side with the sealing pad (5). Bend the pad over the insulation for fitting (union) from above.

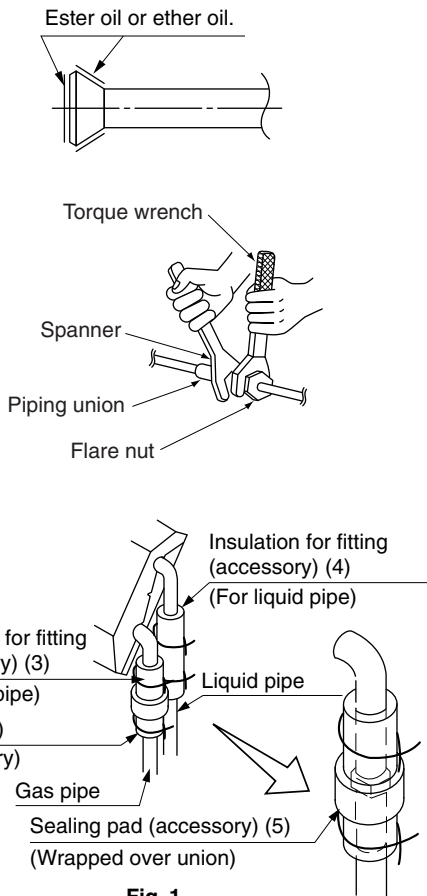

Fig. 1

Use Table 3 as a reference if a torque wrench is not available. Once work is complete, make sure there is no gas leaking. As the flare nut is tightened with the wrench, the torque suddenly increases. From that position, tighten the nut to the angle shown on Table 3 .

- Make absolutely sure to execute heat insulation works on the pipe-connecting section after checking gas leakage by thoroughly studying the following figure and using the attached heat insulating materials for fitting (3) and (4). (Fasten both ends with the clamps (6) (accessory).) **(Refer to Fig. 1)**

CAUTION

- Be sure to insulate any field piping all the way to the piping connection inside the unit. Any exposed piping may cause condensate or burns if touched.

CAUTION TO BE TAKEN WHEN BRAZING REFRIGERANT PIPING

Do not use flux when brazing refrigerant piping. Therefore, use the phosphor copper brazing filter metal (BCuP) which does not require flux.

Flux has an extremely negative effect on refrigerant piping systems. For instance, if chlorine based flux is used, it will cause pipe corrosion. If the flux contains fluorine, it will damage the refrigerant oil.

DANGER

- Use of oxygen may cause an explosion resulting in serious injury or death. Only use nitrogen gas.
- Refrigerant gas may produce toxic gas if it comes in contact with fire such as from a fan heater, stove or cooking device. Exposure to this gas could cause severe injury or death.
- Before brazing local refrigerant piping, nitrogen gas shall be blown through the piping to expel air from the piping. If brazing is done without nitrogen gas blowing, a large amount of oxide film develops inside the piping, and could cause system malfunction.
- When brazing the refrigerant piping, only begin brazing after having carried out nitrogen substitution or while inserting nitrogen into the refrigerant piping. Once this is done, connect the indoor unit with a flared or a flanged connection.
- Nitrogen should be set to 2.9 psi with a pressure-reducing valve if brazing while inserting nitrogen into the piping.

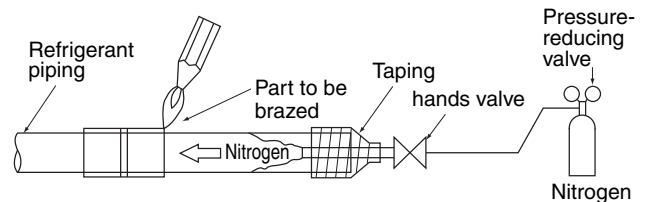

NOTE

Use the flare nuts attached with the unit. Not recommended but if no torque wrench is available, refer to table 2 for tightening torque:

Table 2

Pipe size	Tightening torque (ft-lbf)	Flare dimensions A (in.)	Flare shape (in.)
φ 1/4"	10.5 – 12.7	0.343 – 0.358	
φ 3/8"	24.1 – 29.4	0.504 – 0.520	
φ 1/2"	36.5 – 44.5	0.638 – 0.654	
φ 5/8"	45.6 – 55.6	0.760 – 0.776	

Not recommendable but in case of emergency

You must use a torque wrench but if one is not available, you may follow the installation method mentioned below.

After the work is finished, make sure to check that there is no gas leak.

When you keep on tightening the flare nut with a spanner, there is a point where the tightening torque suddenly increases. From that position, further tighten the flare nut at the angle shown below:

Table 3 (in.)

Pipe size	Further tightening angle	Recommended arm length of tool
φ 1/4"	60 to 90 degrees	Approx. 5 7/8
φ 3/8"	60 to 90 degrees	Approx. 7 7/8
φ 1/2"	30 to 60 degrees	Approx. 9 13/16
φ 5/8"	30 to 60 degrees	Approx. 11 13/16

7. DRAIN PIPING WORK

Install the drain pipe as shown below and take measures against condensate. Improperly installed piping can leak on furniture and belongings.

(1) Install the drain piping:

Connect the drain hose (1) using the attached hose and parts, as shown in the drawing to the right.

Piping process inside unit

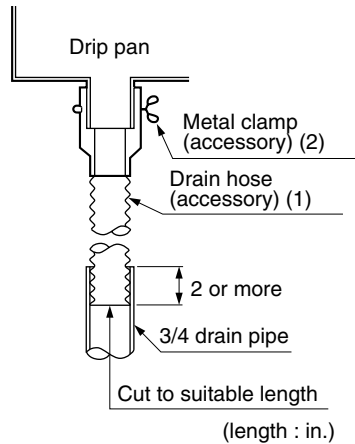
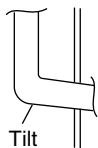

• If converging multiple drain pipes, install according to the procedure shown below.

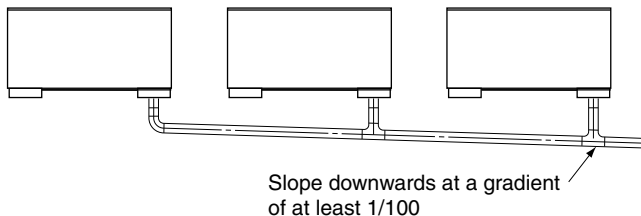

Select converging drain pipes with gauges suitable for the operating capacity of the unit.

(2) After piping work is finished, check that drainage flows smoothly.

- Add approximately 1 liter of water slowly from the air outlet and check drainage flow.

(3) Be sure to insulate all indoor pipes

CAUTION

- Drain piping connections
Do not connect the drain piping directly to sewage pipes that smell of ammonia. The ammonia in the sewage might enter the indoor unit through the drain pipes and corrode the heat exchanger.
- Keep in mind that water collecting on the drain pipe causes blockage.

8. ELECTRIC WIRING WORK

8-1 GENERAL INSTRUCTIONS

- All field supplied parts and materials, electric works must conform to local codes.
- Use copper wire only.
- Follow the WIRING DIAGRAM attached to the unit to wire the outdoor unit, indoor units and the remote controllers. For details on hooking up the remote controller, refer to the **INSTALLATION MANUAL OF REMOTE CONTROLELR.**
- All wiring must be performed by an authorized electrician.
- This system consists of multiple indoor units. Mark each indoor unit as unit A, unit B, and so forth, and be sure the terminal block wiring to the outdoor unit and BS unit is properly matched. If controls wiring and piping between the outdoor and indoor units are mismatched, a communications malfunction is likely. A circuit breaker capable of shutting down the power supply to the entire system must be installed.
- Be sure to ground the air conditioner.

DANGER

- Do not ground units to water pipes, telephone wires, or lightning rods because incomplete grounding and lightning strikes can cause a severe shock hazard resulting in severe injury or death., Do not ground units to gas pipes because a gas leak can result in an explosion leading to severe injury or death.

8-2 ELECTRICAL CHARACTERISTICS

Units				Power supply		Fan motor	
Model	Hz	Volts	Voltage range	MCA	MFA	W	FLA
FXLQ12MVJU, FXNQ12MVJU	60	208-230	Max. 253 Min. 187	0.5	15	25	0.4
FXLQ18 · 24MVJU, FXNQ18 · 24MVJU				0.6	15	35	0.5

MCA: Min. Circuit Amps (A); MFA: Max. Fuse Amps (A)
W: Fan Motor Rated Output (W); FLA: Full Load Amps (A)

8-3 SPECIFICATIONS FOR FIELD SUPPLIED FUSES AND WIRE

Model	Power supply wiring		Remote controller wiring Transmission wiring	
	Field fuses ⊞	Size	Wire	Size

FXLQ12 · 18 · 24 MVJU	15A	Size must comply with local codes.	Sheathed wire (2 wire)	AWG 18-16
FXNQ12 · 18 · 24 MVJU				

NOTE

- Allowable length of transmission wiring between indoor / outdoor units and between the indoor unit and the remote controller is as follows.
 - Outdoor unit – Indoor unit:
Max. 3280 ft. (Total wiring length: 6560 ft.)
 - Indoor unit – Remote controller:
Max. 1640 ft.
- Insulated thickness: 1/16" or more.

9. WIRING EXAMPLE AND HOW TO SET THE REMOTE CONTROLLER

9-1 HOW TO CONNECT WIRINGS

- Remove the electric parts box lid and connect the wirings.

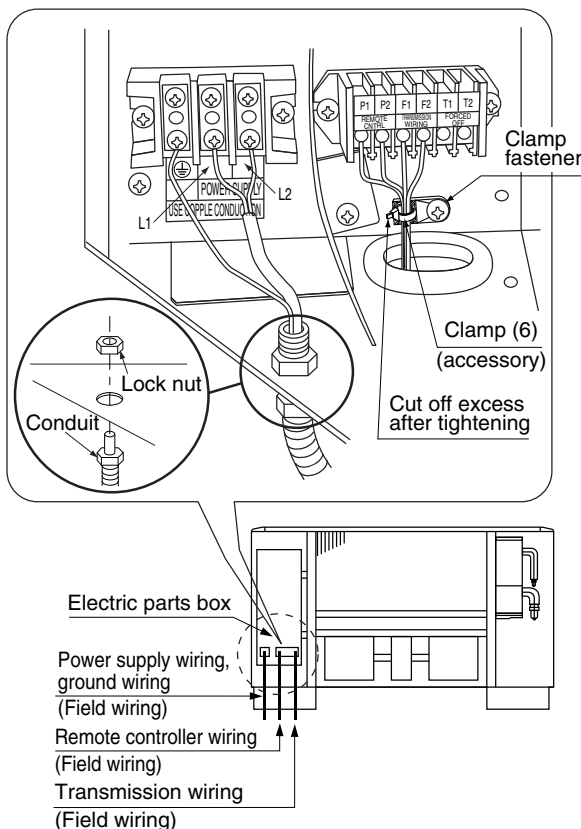

NOTE

- For wiring to the electric parts box, see the **WIRING DIAGRAM** label on the back of the electric parts box lid.
- Do not confuse remote controller wiring and transmission wiring when connecting to the terminal block.
- Fasten the wiring with accessory clamp (6).

- If mounting a remote controller on the unit, wire as shown in the figure on the right.

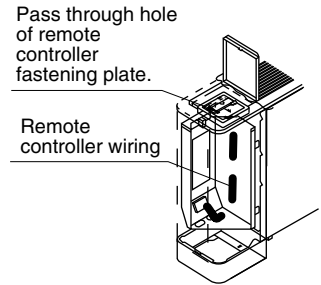

CAUTION

- Never connect power supply wiring to the terminal block for remote controller wiring as this could damage the entire system.
- Use only specified wire and connect wires to the terminal tightly. Be careful wires do not place external stress on terminals. Keep wires in neat order so as to not obstruct other equipment. Make sure that the electric box lid fits tightly. Incomplete connections could result in overheating and, in worse case, result in electric shock or fire.

NOTE

- To avoid a short circuit in the electric parts box, be sure to apply sealing material or putty (not included) to the wiring hole to prevent the infiltration of water as well as insects or other small creatures. Otherwise a short-circuit may occur inside the electric parts box.
- When clamping the wirings, be sure no tension is applied to the wire connections by using the included clamps. Also, when wiring, make sure the electric parts box lid fits snugly by arranging the wirings neatly and attaching the electric parts box lid firmly. When attaching the electric parts box lid, make sure no wirings get caught in the edges. Pass the wirings through the hole to prevent damage.

Make sure the remote controller wiring, the wiring between the units, and other electric wiring do not pass through the same locations outside of the unit, separating them by at least 5", to prevent the possibility of electric noise (external static) causing faulty operation or breakage.. **PRECAUTIONS**

1. Use round crimp-style terminals for connecting wires to the power supply terminal block.
If unavailable, observe the following points when wiring.
 - Do not connect wires of different gauges to the same power supply terminal. Looseness in the connection may cause overheating.
 - Use the specified electric wire. Connect the wire securely to the terminal. Lock the wire down without applying excessive force to the terminal. (Tightening torque: 0.97ft.lbf ±10 %)

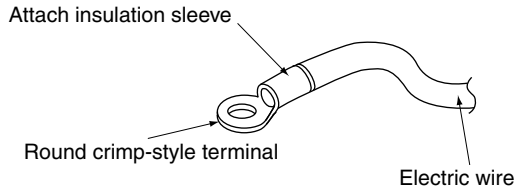

2. Tightening torque for the terminal screws.

- Use the correct screwdriver for tightening the terminal screws. If the blade of screwdriver is too small, the head of the screw might be damaged, and the screw will not be properly tightened.
- If the terminal screws are tightened too hard, they might be damaged.
- Refer to the table below for the tightening torque of the terminal screws.

Terminal	Size	Tightening torque (ft-lbf)
Terminal block for remote controller (6P)	M3.5	0.58 – 0.72
Power supply terminal block (2P)	M4	0.87 – 1.06
Ground terminal	M4	1.06 – 1.43

3. Do not connect wires of different gauge to the same grounding terminal. Looseness in the connection may deteriorate protection.
4. Outside of the unit, keep transmission wiring at least 5" away from power supply wiring. The equipment may malfunction if subjected to electric (external) noise.
5. For remote controller wiring, refer to the **INSTALLATION MANUAL OF REMOTE CONTROLLER.**

9-2 WIRING EXAMPLE

- Fit the power supply wiring of each unit with a switch and fuse as shown in the drawing.

COMPLETE SYSTEM EXAMPLE (3 SYSTEMS)

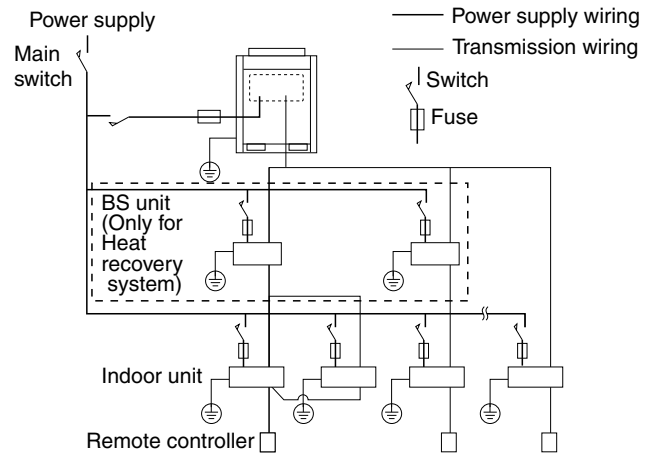

1. When using 1 remote controller for 1 indoor unit. (Normal operation)

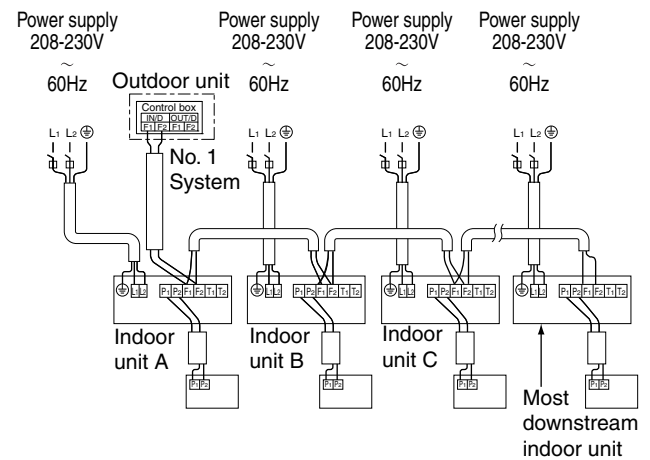

2. For group control or use with 2 remote controllers

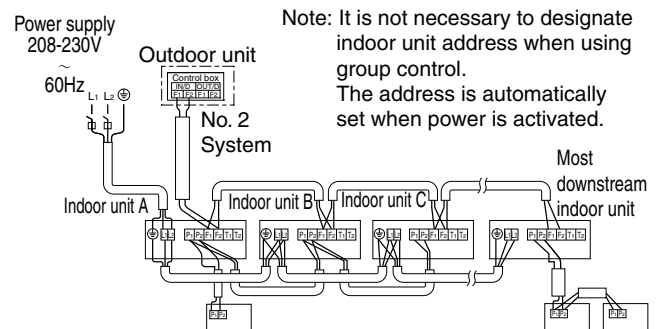
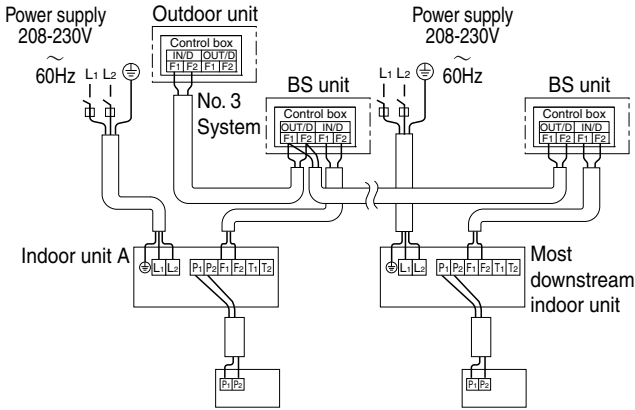

Fig. 2

For use with 2 remote controllers

3. When including BS unit



- NOTE**
1. A single switch can be used to supply power to units on the same system. However, branch switches and branch circuit breakers must be selected carefully.
 2. Do not ground the equipment on gas pipes, water pipes, lightning rods or telephone ground wires. Improper grounding could result in electric shock.

9-3 CONTROLLING 1 INDOOR UNIT BY 2 REMOTE CONTROLLERS

- When using 2 remote controllers, one must be set to "MAIN" MAIN and the other to SUB.

MAIN/SUB CHANGEOVER

- (1) Insert a \ominus screwdriver into the recess between the upper and lower part of remote controller, and working from the 2 positions, pry off the upper part. The remote controller PC board is attached to the upper part of remote controller.

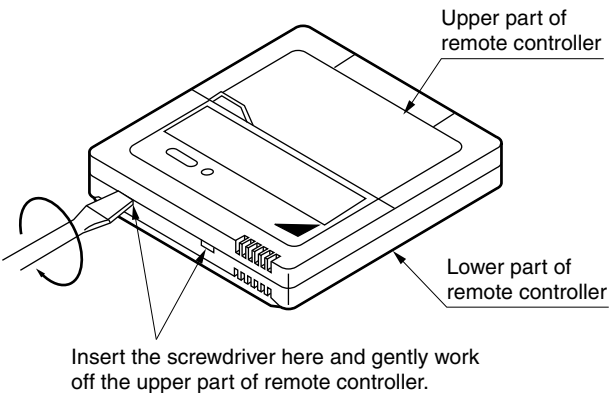

- (2) Turn the MAIN/SUB changeover switch on one of the two two remote controllers PC board to [S]. Leave the switch of the other remote controller set to [M].

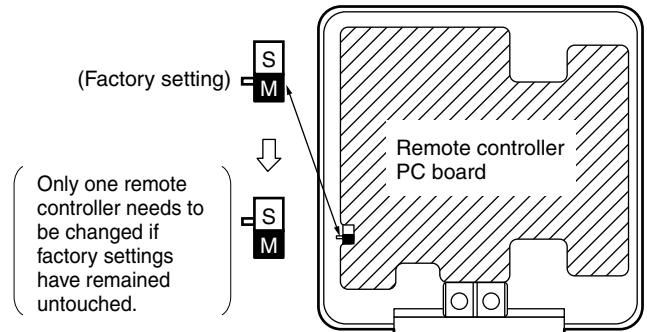

Wiring Method (See "8. ELECTRIC WIRING WORK")

- (3) Remove the electric parts box lid
- (4) **Add remote control 2 (slave) to the terminal block for remote controller (P₁, P₂) in the electric parts box. There is no polarity.** (Refer to Fig. 2 and 8-3.)

9-4 COMPUTERIZED CONTROL (FORCED OFF AND ON/OFF OPERATION)

- (1) **Wire specifications and how to perform wiring**
 - Connect input from outside to terminals T1 and T2 of the terminal block for remote controller.

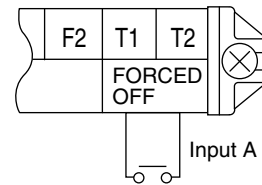

Wire specification	2-conductor, stranded, non-shielded copper cable / PVC or vinyl jacket
Gauge	AWG18
Length	Max. 328 ft.
External terminal	Contact that can ensure the minimum applicable load of 15 V DC, 10 mA.

- (2) **Actuation**
 - The following table explains FORCED OFF and ON/OFF OPERATIONS in response to Input A. The T1-T2 terminals are standard on all Daikin indoor units and allow for remote starting and stopping of equipment. Individual indoor units can be field programmed at the remote controller to change the T1-T2 sequence of operation of the equipment based upon the application..

FORCED OFF (Manual Restart)	ON/OFF OPERATION
Mode No. 12	Mode No. 12
First Code No. 1	First Code No. 1
Second Code No. 01	Second Code No. 02
DEFAULT SETTING	

<p>Input A OFF (Open Circuit)</p> <p>An open circuit between terminals T1 and T2 allows the unit to run normally.</p>	<p>Input A OFF (Open Circuit)</p> <p>An open circuit between terminals T1 and T2 prevents unit operation.</p>
<p>Input A ON (Closed Circuit)</p> <p>Closing the normally open circuit between terminals T1 and T2 stops operation of the unit. When T1-T2 is opened, the unit must be restarted with the remote controller.</p>	<p>Input A ON (Closed Circuit)</p> <p>A closed circuit between terminals T1 and T2 allows normal operation of the unit.</p>

(3) How to select FORCED OFF and ON/OFF

- Turn the power on and then use the remote controller to select operation. These codes are programmed at the remote controller. Individual unit groups can be programmed independently.

9-5 CENTRALIZED CONTROL

- For centralized control, it is necessary to designate the group No. For details, refer to the manual of each optional controller for centralized control.

10. FIELD SETTING

Make sure the electric parts box lids are closed on the indoor and outdoor units.

Field setting must be made from the remote controller in accordance with the installation condition.

- Setting can be made by changing the **Mode No.**, **FIRST CODE NO.**, and **SECOND CODE NO.**
- For setting and operation, refer to the **FIELD SETTING** section in the installation manual of the remote controller.

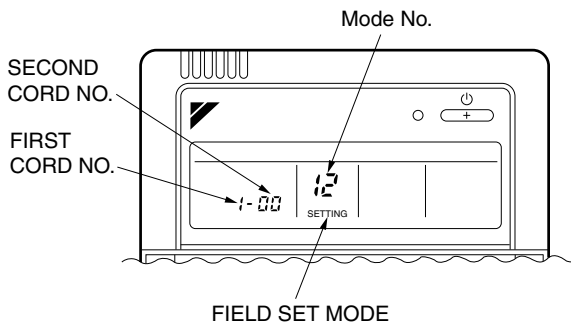

- Set the remote controller to the field set mode. For details, refer to **HOW TO SET IN THE FIELD** in the remote controller manual.
- When in the field set mode, select mode No. 12, then set the first code (switch) No. to [1]. Then set second code (position) No. to [01] for FORCED OFF and [02] for ON / OFF OPERATION. (FORCED OFF at factory set)

11. TEST OPERATION

Make sure the service lids are closed on the indoor and outdoor units.

Refer to the installation manual of the outdoor unit.

- The operation lamp of the remote controller flashes when a malfunction occurs. Check the malfunction code on the liquid crystal display to identify the point of trouble. An explanation of malfunction codes and the corresponding trouble is provided in the installation manual of the outdoor unit.
If any of the items in Table 4 are displayed, there may be a problem with the wiring or power, so check the wiring again.

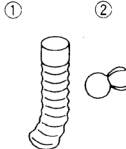
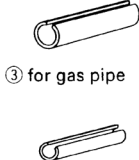
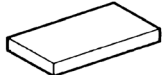

Table 4

Remote control display	Content
Under Centralized Control is lit	<ul style="list-style-type: none"> • There is a short circuit at the FORCED OFF terminals (T1, T2)
<p>U4 is lit UH is lit</p>	<ul style="list-style-type: none"> • The power on the outdoor unit is off. • The outdoor unit has not been wired for power supply. • Incorrect wiring for the transmission wiring and / or FORCED OFF wiring. • The transmission wiring is cut.
<p>No display</p>	<ul style="list-style-type: none"> • The power on the indoor unit is off. • The indoor unit has not been wired for power supply. • Incorrect wiring for the remote controller wiring, the transmission wiring and / or the FORCED OFF wiring. • The remote controller wiring is cut.

- If **U3** is lit, the malfunction code shows the test operation has not been performed yet.

10. Accessories

Standard Accessories

Name	Drain hose	Insulation for fitting	Sealing pad	Clamp	Level adjust-ment screw	(Other)
Quantity	1 set	1 set	1 set	8	4	<ul style="list-style-type: none"> • Operation manual • Installation manual
Shape	 <p>Hose × 1 Clamp metal × 1</p>	 <p>③ for gas pipe ④ for liquid pipe</p>	 <p>⑤</p>	 <p>⑥</p>	 <p>⑦</p>	

3P086154-3J

Optional Accessories (For Unit)

No.	Item	Type	FXLQ12MVJU FXNQ12MVJU	FXLQ18MVJU FXNQ18MVJU	FXLQ24MVJU FXNQ24MVJU
1	Long life replacement filter		KAFJ361K45	KAFJ361K71	

4D045647

For Controller Optional Accessories, Refer to *Controller Manual*.

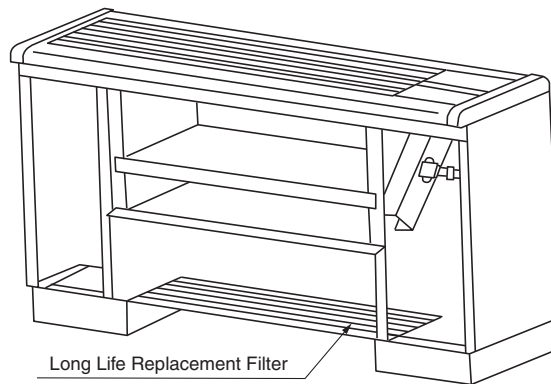

(V0683)

Warning



- Daikin Industries, Ltd.'s products are manufactured for export to numerous countries throughout the world. Daikin Industries, Ltd. does not have control over which products are exported to and used in a particular country. Prior to purchase, please therefore confirm with your local authorized importer, distributor and/or retailer whether this product conforms to the applicable standards, and is suitable for use, in the region where the product will be used. This statement does not purport to exclude, restrict or modify the application of any local legislation.
- Ask a qualified installer or contractor to install this product. Do not try to install the product yourself. Improper installation can result in water or refrigerant leakage, electrical shock, fire or explosion.
- Use only those parts and accessories supplied or specified by Daikin. Ask a qualified installer or contractor to install those parts and accessories. Use of unauthorized parts and accessories or improper installation of parts and accessories can result in water or refrigerant leakage, electrical shock, fire or explosion.
- Read the User's Manual carefully before using this product. The User's Manual provides important safety instructions and warnings. Be sure to follow these instructions and warnings.

If you have any inquiries, please contact your local importer, distributor and/or retailer.



© 2004 Daikin Industries, Limited.

Daikin®, Daikin AC™, Absolute Comfort™, VRV® and REFNET™ are trademarks pending or registered trademarks of Daikin Industries, Limited. All rights reserved. LowWorks® and LON® are registered trademarks of Echelon Corporation. BACnet® is a Data Communication Protocol for Building Automation and Control Networks, developed under the auspices of the American Society of Heating, Refrigerating and Air-Conditioning Engineers (ASHRAE).



JMI-0107



JQA-1452

About ISO9001

ISO 9001 is a plant certification system defined by the International Organization for Standardization (ISO) relating to quality assurance. ISO 9001 certification covers quality assurance aspects related to the "design, development, manufacture, installation, and supplementary service" of products manufactured at the plant.



EC99J2044



JQA-E-90108

About ISO 14001

ISO 14001 is the standard defined by the International Organization for Standardization (ISO) relating to environmental management systems. Our group has been acknowledged by an internationally accredited compliance organisation as having an appropriate programme of environmental protection procedures and activities to meet the requirements of ISO 14001.

Dealer

DAIKIN AC (AMERICAS), INC.
1645 Wallace Drive, Suite 110
Carrollton, TX75006
info@daikinac.com
www.daikinac.com

©All rights reserved

● Specifications, designs and other content appearing in this brochure are current as of May 2007 but subject to change without notice.